

REV	DATE	CHANGE DESCRIPTION	MOD. BY	CK1	CK2
F	07/06/2005	CHANGED TO BOLTED INSERTS.	ZS	RJH	HM

PT# 123008-E02  
 S.A.E. HOUSING MOUNT 27/64 DRILL THRU  
 12 HOLES EQUALLY SPACED ON 15.00 B.C.  
 4" PUMP PILOT S.A.E. "B" PUMP MOUNT.  
 (2) 1/2-13 TAPPED HOLES EQUALLY  
 SPACED ON 5.75 B.C.

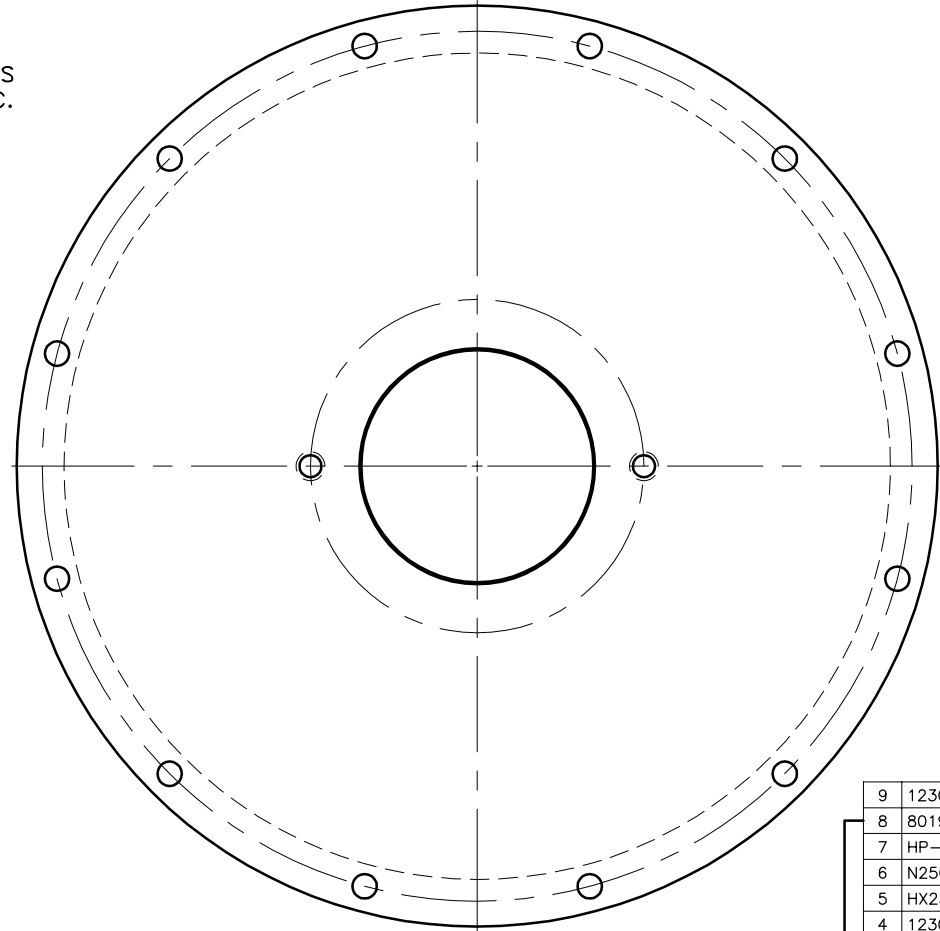
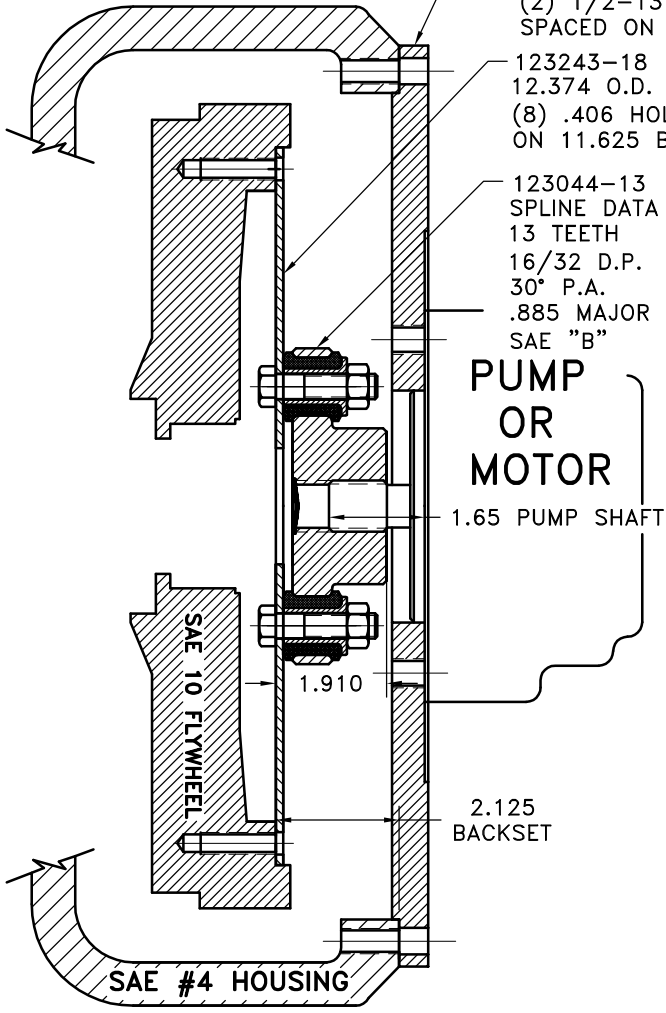

COUPLING ASS'Y #124045

UP TO 110 H.P.

QTY.	PART NUMBER	DESCRIPTION
1	123008-E02	PUMP MOUNT PLATE [4]
1	801912	GREASE
1	HP-1125-S-32	HUBBARD PLUG
6	N250	7/16-20 NUT
6	HX230	7/16-20 x 1 3/4" HHB
6	123000-00	STEEL BUSHING
6	H62500	NEOPRENE INSERT
1	123044-13	COUPLING HUB
1	123243-18	FLYWHEEL PLATE

SYMBOLS	DET.	PART NUMBER	DESCRIPTION	QTY.
FLATNESS STRAIGHTNESS ANGULARITY SQUARENESS PARALLELISM CONCENTRICITY TRUE POSITION ROUNDNESS CIRCULAR RUN OUT TOTAL RUN OUT CYLINDRICITY FINISH	DO NOT SCALE DRAWING TOLERANCES UNLESS OTHERWISE SPECIFIED MAXIMUM ANGLE ±1/2° FRACTION ±1/32 DECIMAL .00 ±.01 .000 ±.005 .0000 ±.0005			
			TITLE FLYWHEEL COUPLING ASSY WITH PUMP MOUNT PLATE MATERIAL	
			DRAWN BY SIETING	DATE 03-31-94
			CHECKED BY RJH	SCALE DRAWING NO. 124168 SHEET OF REV.

THIS DRAWING IS THE PROPERTY OF HAYES MFG. INC. AND IS LOANED SUBJECT TO THE CONDITION THAT IT SHALL NOT BE REPRODUCED, COPIED, LOANED OR OTHERWISE DISPOSED OF, DIRECTLY OR INDIRECTLY. IT SHALL BE USED AS A MEANS OF REFERENCE TO WORK FURNISHED BY THIS COMPANY ONLY AND IS NOT TO BE SUBMITTED TO OUTSIDE PARTIES FOR EXAMINATION WITHOUT OUR CONSENT.